Product Specifications

Type : Reflowable ML Lithium Rechargeable Battery

Model : ML414H IV01E

This is a "Standard Spec sheet " which is a general documentation for your evaluation.

Before we will start to supply this part to you, we would like you to ask us the formal version of this spec sheet.

We will issue the formal specification sheet for you.

(Basically the contents is the same as this one.)

We would like you to put your signature on it to state your approval of the specification, and send it back to us.

Seller: **Seiko Instruments Inc.**
Electronic Components Sales Head Office

History of Revision

No.	Details of Change	Issue Date
01	Initial Release for Standard specifications	May.9.2017

Manufacturer information

Company name: Seiko Instruments Inc.
Micro-Energy Division

Address: 45-1, Aza-Matsubara, Kami-ayashi, Aoba-ku, Sendai-shi,
Miyagi, Japan, postal code: 989-3124

Index

Contents	Page
Cover page	1
History of Revision Manufacturer Information	2
Index	3
1. Application	4
2. Model	4
3. Chemical System and Structure	4
4. Nominal Specifications	4
5. Characteristics Electric characteristics Mechanical characteristics Reliability Parameter for Test and Measuring	5
6. Measuring Methods	7
7. Test Methods	8
8. Mounting Conditions	9
9. Indications (Markings)	9
10. Inspection	10
11. Package Specifications	10
12. In case of quality trouble	10
13. Operation of this Specification	10

Appendix

Leakage Criteria
 Construction of Battery
 Battery drawing with tabs
 Explanation for co-planarity
 Reflow Profile
 Drawing of Emboss Carrier Tape
 Battery position in emboss tape
 Taping specifications
 Package specifications
 Precautions for Your Safety

1. Application

This specification applies to the Reflowable ML Lithium Rechargeable Battery, which is manufactured and supplied by Seiko Instruments Inc. to the customer specified in the cover page of this document.

2. Model

Model described in cover.

3. Chemical System and Structure

Refer to the document "The construction of battery" attached.

4. Nominal Specifications

		Model
No.	Characteristics	ML414H
4-1	Range of temperature in which it can function	From -20°C to 60°C
4-2	Recommended temperature range for use	From 0°C to 30°C
4-3	Recommended range of preservation temperature and humidity	From 10°C to 30°C 60%RH or less
4-4	Nominal voltage	3V
4-5	Charging voltage	From 2.7V to 3.1V
4-6	Recommended Charging voltage	3.1V
4-7	Nominal capacity: after charging(mAh) From 3.1V to 2.0V	1.0
4-8	Standard Discharge Current (mA)	0.005
4-9	Nominal dimensions Diameter (mm) Height (mm)	4.8 1.4
4-10	Standard mass (g)	0.07 (without tabs)
4-11	Applicable Safety Standard	UL1642 (File No.MH15628)

5. Characteristics

* "Initial" means within one month after deliver.

* Attached "Leakage Criteria" is used for the judgment of leakage.

5-1. Electric characteristics

No.	Characteristics	Model	Test Methods	Measuring Methods
		ML414H		
1	Open Circuit Voltage (V) at delivery		7-1	6-4
	Maximum	2.8		
	Minimum	2.3		
2	Open Circuit Voltage (V) after charge		7-1	6-2 1) 6-4
	Maximum	3.1		
	Minimum	2.8		
3	Initial Capacity (mAh)		7-2	6-2
	24°C	0.8 or more		
	-20°C	0.2 or more		
4	Initial Internal Impedance (ohm)		7-2	6-3
	24°C	1500 or less		
	-20°C	5000 or less		
	60°C	1500 or less		

5-2. Mechanical characteristics

No.	Characteristics	Model	Test Methods	Measuring Methods
		ML414H		
1	Tab Pulling Strength (N): With the terminal		-	6-8
	-	Refer to Battery Drawing with tabs attached		
2	External Appearance		7-1	6-9
	Initial	No leakage There must not be foreign body adhesion (over level S2). There is no significant deformation, stain, stricken mark, rust and burr.		
	After Tests	There is no significant leakage (over level C1), deformation, stain, stricken mark, rust and burr.	7-3 7-4	
3	Free fall	Satisfy initial capacity and internal impedance. There is no significant leakage, deformation, stain, stricken mark, rust and burr, which effect battery performance.	7-8	6-2 6-3 6-9
4	Vibration	Satisfy initial capacity and internal impedance. There is no significant leakage, deformation, stain, stricken mark, rust and burr, which effect battery performance.	7-9	6-2 6-3 6-9

5-3. Reliability

No.	Characteristics	Model	Test Methods	Measuring Methods
		ML414H		
1	High Temperature Storage Characteristics		7-3	6-2
	Capacity (mAh)	0.68 or more		
2	Float Charge Characteristics		7-4	6-2 6-3
	Capacity (mAh)	0.68 or more		
	Internal Impedance (ohm)	3000 or more		
3	Over Discharge Characteristics		7-5	6-2
	Capacity (mAh)	0.68 or more		
4	Charge / Discharge Cycle Characteristics (Cycles)			6-2
	10% D.O.D.	300cycle or more	7-6	
5	Leakage Resistance	Level S3 or less (There is no significant leakage which effect battery performance.)	7-7	6-9

5-4. Table of Parameter for Test and Measuring

No.	Characteristics	Model	Test Methods	Measuring Methods
		ML414H		
1	Capacity		-	6-2
	Vc (V)	3.1		
	Rp (kohm)	3		
	Tc (hrs)	72		
	Rd (kohm)	470		
	Voff (V)	2.0		
2	Float Charge Characteristics		7-4	
	Vc (V)	3.1		
	Rp (kohm)	3		
3	Over Discharge Characteristics		7-5	
	Rs (kohm)	33		
4	Charge / Discharge Cycle		7-6	
	Vc (V)	3.1		
	Rp (kohm)	3		
	Tcs (hrs)	5		
	Rds (kohm)	100		
	Tds (hours)	4		

6. Measuring Methods

6-1. General Conditions

The measuring conditions are temperature of 24+/-2 °C, humidity of 65+/-20%Rh and within one month after delivering, if not specified.

6-2. Capacity

- 1) Charging: Apply specified voltage (V_c) through the protective resistance (R_p) for specified time (T_c).
- 2) Discharging: Discharging with load resistance (R_d) until the cell voltage reaches the cut off voltage (V_{off}), the cell voltage (V_i) and time (T_i) should be measured at intervals within one hour.
- 3) Calculation: The capacity value is calculated by the expression below.

$$Capacity = \sum_i \left(\frac{(V_i + V_{i+1})}{2} \times \frac{1}{R_d} \times (T_{i+1} - T_i) \right)$$

- 4) General Circuit: The circuit, for charging and discharging, is shown as follows.

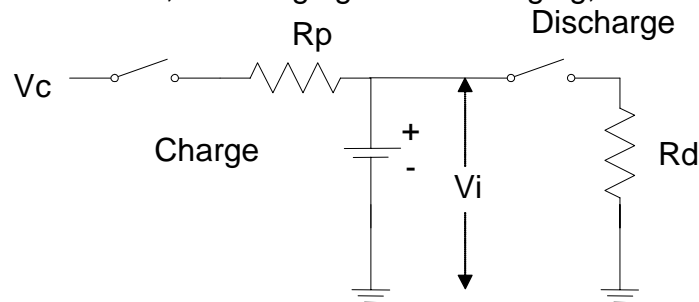

6-3. Internal Impedance

Measure by alternating current method using frequency of 1KHz.

6-4. Voltage

Use a direct current voltage meter, which has input impedance of 10Mohm or more and accuracy of +/-0.2% or less.

6-5. Current

Use an ammeter with accuracy of +/-0.2% or less.

6-6. Resistance

Resistance, which includes resistance of all external circuits, requires accuracy of 2.0% or less.

6-7. Size measurement

Use the size measurement instruments with accuracy of 0.01mm or 0.001mm if necessary.

6-8. Terminal pull strength: The direction of the pull is vertical.

Use a digital force gauge, which has accuracy of +/-1.0% or less.

6-9. Appearance

- | | |
|-------------|--|
| After Test | : Microscope, which has magnification of 10 times. |
| At delivery | : Naked eye |

7. Test Methods

7-1. General conditions

If not specified, the test conditions are temperature of 24 ± 2 °C, humidity of $65\pm 20\%$ Rh and The test should be started within one month after delivering.

7-2. Temperature Characteristics Test

Measure electrical characteristics after exposing battery to each temperature atmosphere for 2 hours.

Temperature: -20 ± 2 °C, $+24\pm 2$ °C, $+60\pm 2$ °C

7-3. High Temperature Storage

After Charging at voltage of V_c through protective resistance of R_p for T_c hours, store battery at temperature 60 ± 2 °C for 20days.

7-4. Float Charge Characteristics Test

Charge battery at voltage of V_c through protective resistance of R_p at temperature of 60 ± 2 °C for 20days.

7-5. Over Discharge Characteristics Test

Discharge the battery by discharge resistance of R_s for 30 days.

7-6. Charge / Discharge Cycle Characteristics Test

Charge : Apply specified voltage (V_c) through protective resistance (R_p) for specified period (T_c).

Discharge : With load resistance (R_d) for specified period (T_d).

The battery is repeated in the above condition. Its closed circuit voltage is 2.00V or more.

7-7. Leakage Resistance (Thermal Shock Test: Air to Air)

Hold battery at -10 ± 2 °C for 1 hour then hold it at 60 ± 2 °C for 1 hour.

Repeat 100 cycles between above conditions. (Chamber) Not humidity controlled.

7-8. Free Fall Test

Drop the battery ten times in an arbitrary direction on the board of the oak of 3cm in thickness from the height of 75cm. The tabs of battery should be cut before test.

7-9. Vibration Test

Vibrate the battery in the direction of 3(x, y, z) for 30 minutes by 1000 cycles per minute with amplitude of 2mm. The tabs of battery should be cut before test.

8. Mounting Conditions

Reflow soldering
Refer to "Reflow Profile" attached.

9. Indications (Markings)

9-1. Dies

Following items are indicated on battery.

Below items can be omitted except item (2).

- | | |
|-------------------------------------|--------------------------|
| (1) Model code | (2) Cathode polarity (+) |
| (3) Manufacturer's name or monogram | (4) Country of origin |

9-2. Date of Manufacturing

Date of Manufacturing is marked on the positive tab or the battery (if possible) and label of each package as.

(Example) M51...manufactured in January 2015
M6Y...manufactured in November 2016
M70...manufactured in October 2017

Abbreviation of month: Jan. (1), Feb. (2)... Sep. (9), Oct. (0), Nov. (Y), Dec. (Z)

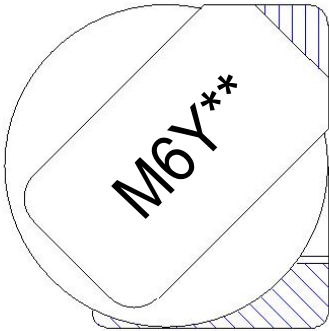

**is our own number, and might be omitted.
Method of marking of manufacturing date is laser type.

10. Inspection

The customer should do incoming inspection within 30 days from receiving day. If defective products are found out at incoming inspection, the customer immediately should notify to Seiko Instruments Inc. in writing with the defective products for replacement request. When there was no contact from you within 30 days, we shall judge that those were accepted.

11. Package Specifications

Examples of the tray or the Emboss tape for wrapping, wrapping specification, and packing specification are shown in the following as our standard.

11-1. Wrapping

Refer to "Drawing of Emboss Carrier Tape", "Battery position in emboss tape" and "Taping specifications".

11-2. Wrapping and packing

Refer to "Package specifications" .

12. In case of quality trouble

The warranties set forth herein are the only warranties on the products.

The liabilities of Seiko Instruments Inc. in connection with the products under these specifications are expressly limited to the replacement of defective products.

13. Operation of this Specification

13-1. Agreement

Before these specifications being revised, the agreement, of the customer, seller and manufacturer, is required.

13-2. Negotiation

If some accident not specified on these specifications occurs, the customer, seller and manufacturer must negotiate in order to solve the problem faithfully.

Leakage Criteria 漏液外觀基準

Grade 級	Criteria 外觀基準	
	Diagram 図	Definition 定義
S1		<p>The leakage can not be seen by naked eyes, but can be seen by microscope, which have magnification of 10 to 15. 肉視で判別不可 顕微鏡（10～15倍）で判別可能なもの</p>
S2		<p>The leakage can be seen by naked eyes. The area of leakage is within half of the round and reaching to neither the flat area of the negative can nor the straight area of the positive can. The leakage is not bridged between the negative can and the positive can. 肉視で判別可能なもの。円周 1/2 まで R 部を超えないこと ブリッジ（正極缶と負極缶）のないこと</p>
S3		<p>The area of leakage is from half to all of the round and reaching to neither the flat area of the negative can nor the straight area of the positive can. The leakage is not bridged between the negative can and the positive can. 円周 1/2 ～全周 R 部を超えないこと ブリッジ（正極缶と負極缶）のないこと</p>
C1		<p>The area of leakage is reaching to either the flat area of the negative can or the straight area of the positive can. The leakage is bridged between the negative can and the positive can. R 部を超えたもの 負極缶のフラット部まで到達 正極缶のストレート部まで到達 ブリッジ（正極缶と負極缶）のあるもの</p>

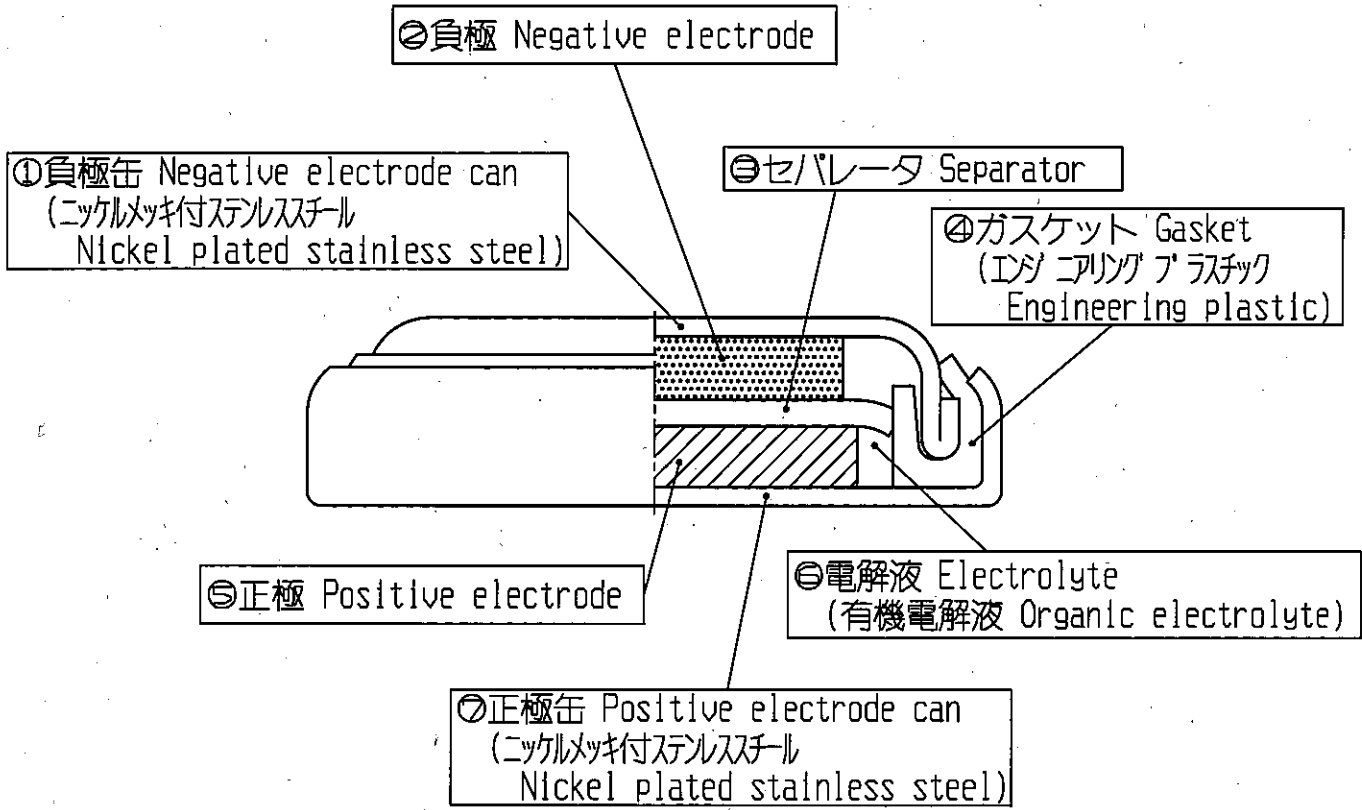

				File No. 文件番号	30460000-ML000-1
				Material 材料	
				Process 処理	
				Date 日付	31. May. '07
E07A-027	31. May. '07	設定		Name 名称	Construction of battery 電池構成図
History 履歴	Date 日付	Reason 理由			
Approved 承認	Checked 検査	Drawn 製図	Scale 尺度	Cal. No. 製品番号	ML***
渡邊	金谷	内藤	Unit 単位	1=1mm	Drw. No. 図面番号
			Rev. 改訂	1	

Seiko Instruments Inc.

(NOTES) 1. TAB pulling strength : Over 9.8N(1.0kgf)
 (注) 1. 端子引張強度 : 9.8N(1.0kgf) 以上

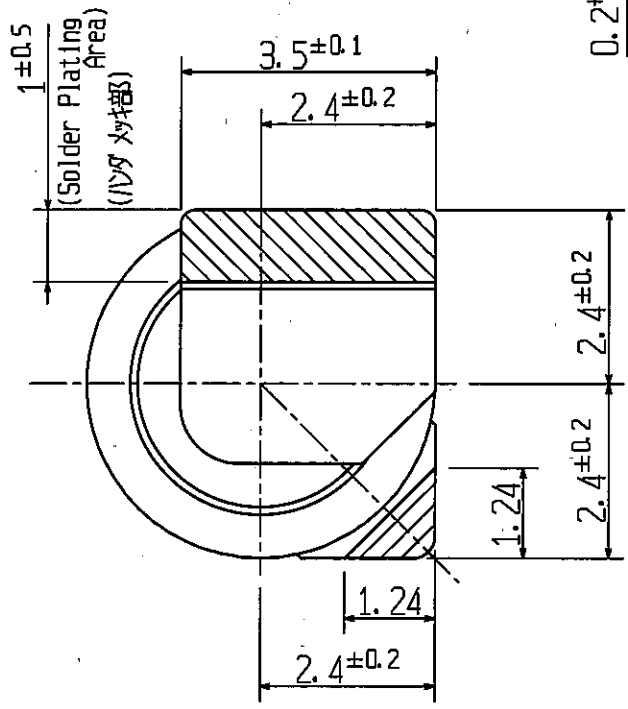
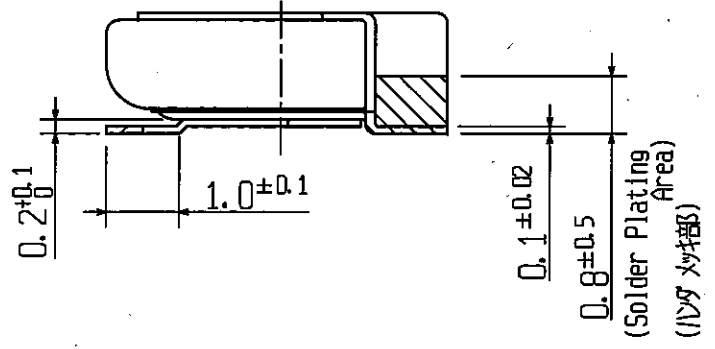
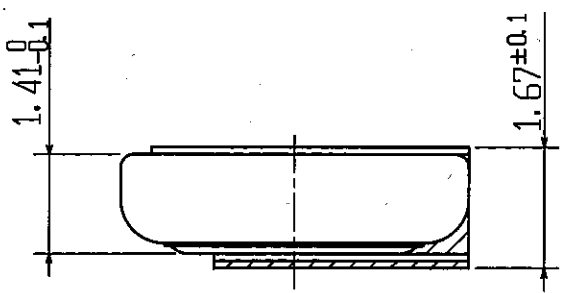
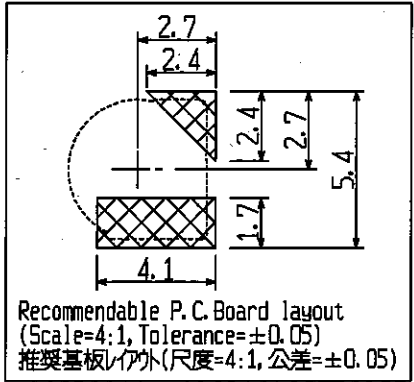
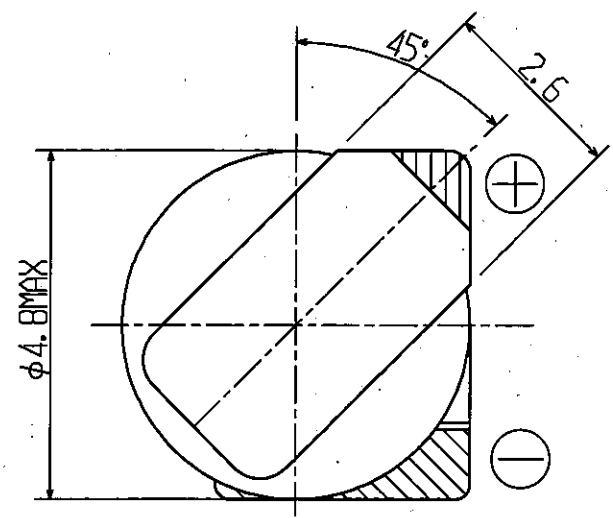

Tolerances of linear dimensions 長さ寸法公差		
Dimension 寸法		Tolerance 公差
0 - 3		±0.20
3 - 6		±0.20
6 - 30		±0.50
Tolerances of angular dimensions 角度寸法公差		
±2°		

				File No. 文件番号	30461090-IV01E-1
				Material 材料	TAB: SUS304-NI·P H/2
				Process 処理	▨ : Solder plating ハンダめっき 2~4μm (Sn 100%)
				Date 日付	10. May. '07
E07A-024	10. May. '07	設定			
History 履歴	Date 日付	Reason 理由			
Approved 承認	Checked 検査	Drawn 製図	Scale 尺度	10:1	Cal. No. 製品番号 ML414H IVO1E
渡邊	金谷	内藤	Unit 単位	1=1mm	
				Rev. 改訂	1
				Drw. No. 図面番号	109 IVO1E

Battery negative side based
電池負極側基準

Gap : +0.36mm
ギャップ : +0.36mm

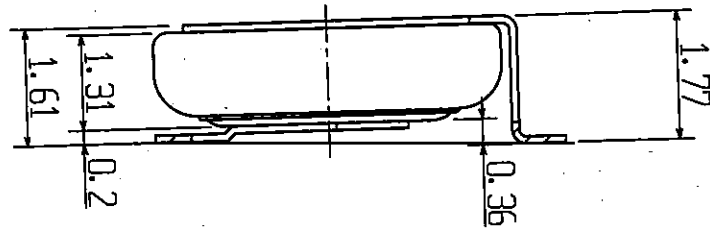

Gap : +0.06mm
ギャップ : +0.06mm

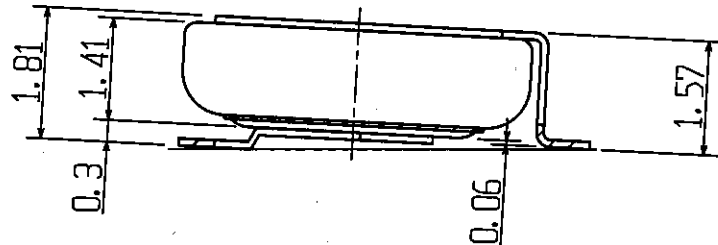

				File No. 文件番号	30461090-IV01EC1
				Material 材料	
				Process 处理	
				Date 日付	10. May. '07
E07A-024	10. May. '07	設定			
History 履歴	Date 日付	Reason 理由			
		Name 名称			
		Explanation of coplanarity 平坦度説明図			
Approved 承認	Checked 検査	Drawn 製図	Scale 尺度	Cal. No. 製品番号	ML414H IV01E
渡邊	金谷	内藤	Unit 単位	1=1mm	Drw. No. 図面番号
			Rev. 改訂	1	

Seiko Instruments Inc.

Reflow Profile

< Reflow Soldering Conditions >

Reflow Soldering Profile: As per shown in Fig.-1.

The times of repeated reflow soldering must be **two times or less**.

The temperature must be measured at top of the cell.

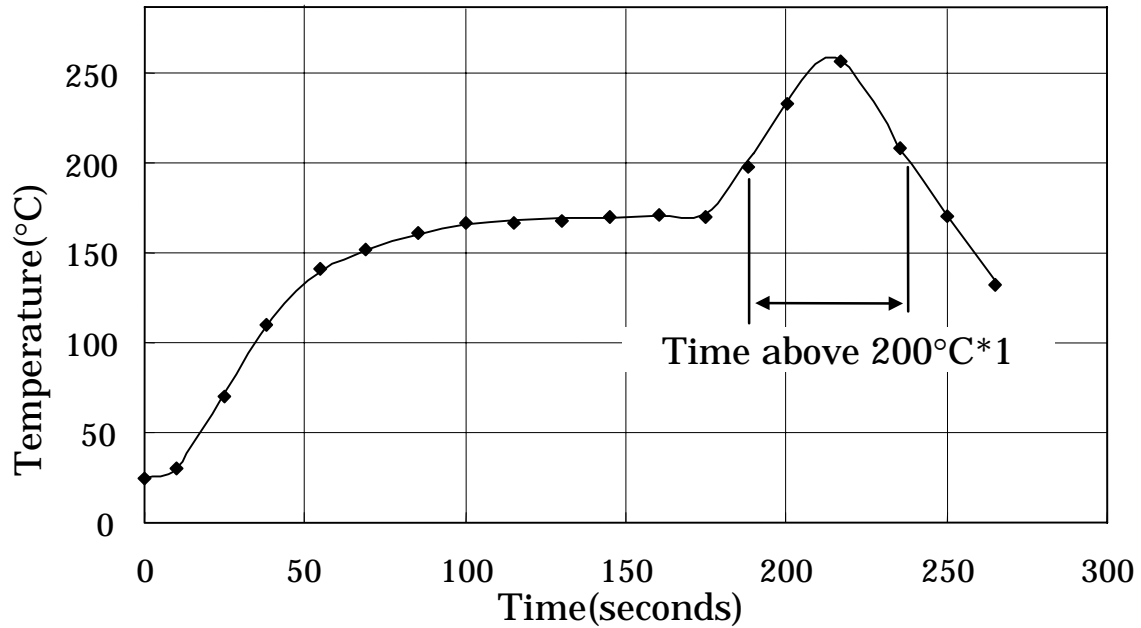

Fig.-1: Reflow soldering profile (for reference only)

*1: Time above 200°C must be max. 80seconds.

Total length of profile must be max. 300seconds.

	Model
Peak Temperature	ML414H
Max.260°C	Applicable (within 5 seconds)

< Underfilling Conditions >

Temperature: Max.160°C, Time: Max.10 minutes.

- (Notes) 1. All fillets not specified : R max 0.3
 2. The plan dimension : the bottom of emboss pocket
 3. Accumulation tolerance of holes: $40 \pm 0.2\text{mm}$ (10 holes)
- 注) 1. 指示のないコーナーは R0.3 以下のこと
 2. 平面図における寸法はエンボスポケット底での寸法である
 3. 送り丸穴累積公差は、10ピッチで $40 \pm 0.2\text{mm}$ とする。

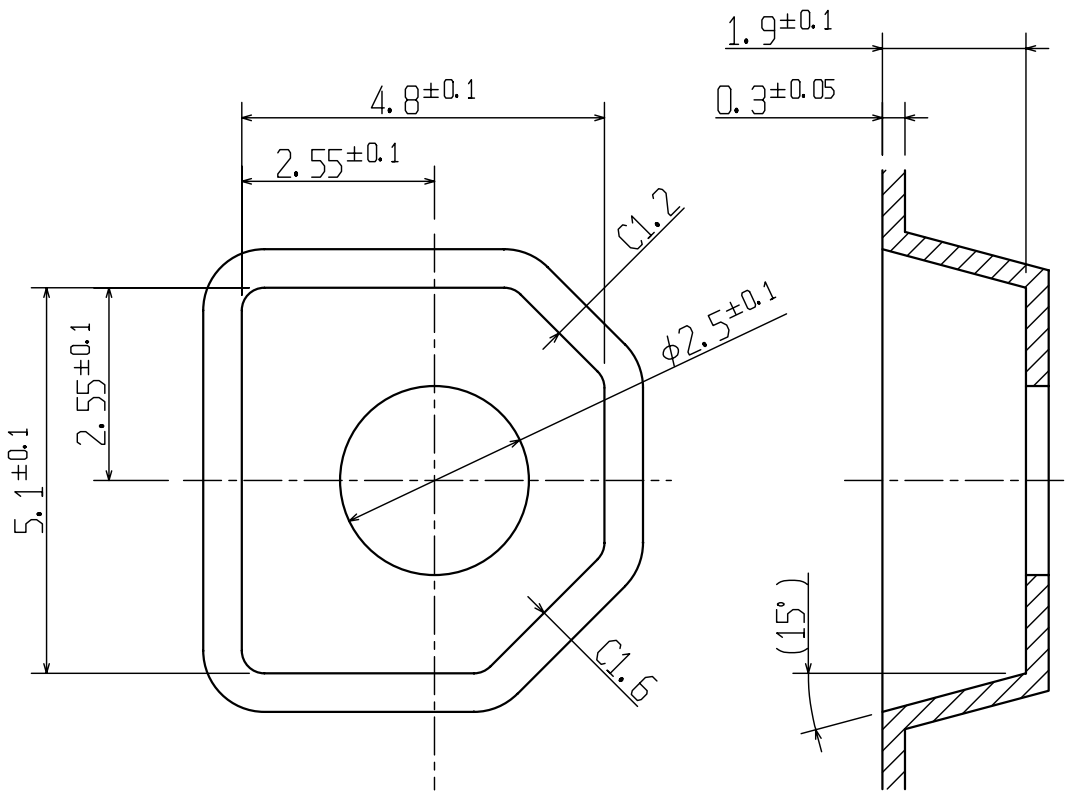
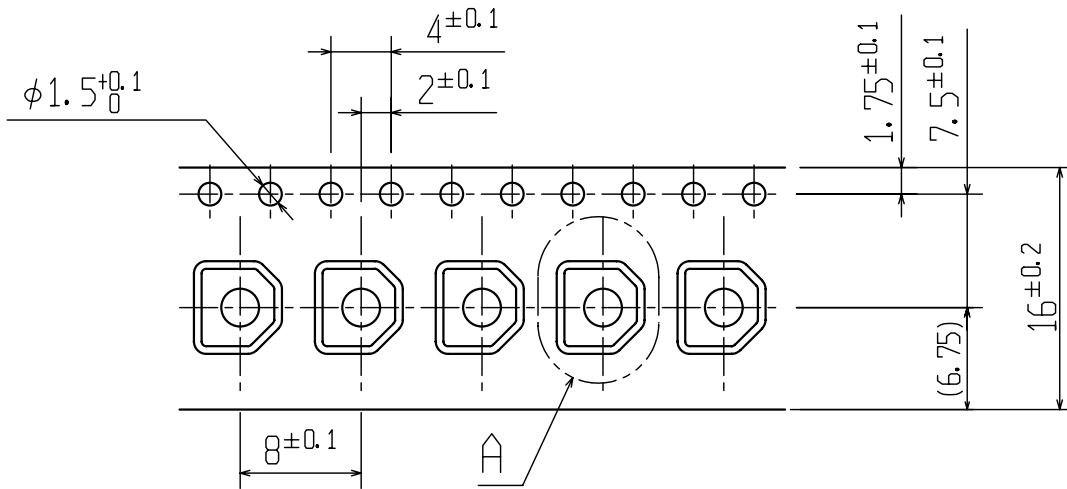

Detail A (10:1)
 詳細 A (10:1)

Tolerances of linear dimensions 長さ寸法公差		
Dimension 寸法		Tolerance 公差
0 - 3		± 0.20
3 - 6		± 0.20
6 - 30		± 0.50
Tolerances of angular dimensions 角度寸法公差		
$\pm 2^\circ$		

				File No. 文件番号	3177N310-00000-2
				Material 材料	Polystyren(Natural) ポリスチレン(ナチュラル)
				Process 処理	16,700 P/R
E09B-014	Apr. 27, 2009	テープ幅公差変更 ($16 \pm 0.3 \rightarrow \pm 0.2$)		Date 日付	Apr. 01, 2007
E08A-010	Apr. 02, 2007	設定		Name 名称	Drawing of emboss carrier tape エンボスキャリアテープ図面
History 履歴	Date 日付	Reason 理由			
Approved 承認	Checked 検査	Drawn 製図	Scale 尺度	2:1	Cal. No. 製品番号
冨塚		尾形	Unit 単位	1=1mm	* * 414
			Rev. 改訂	2	

Battery position in emboss tape

1. Model

ML414H IV01E

2. Battery position in emboss tape

Negative side

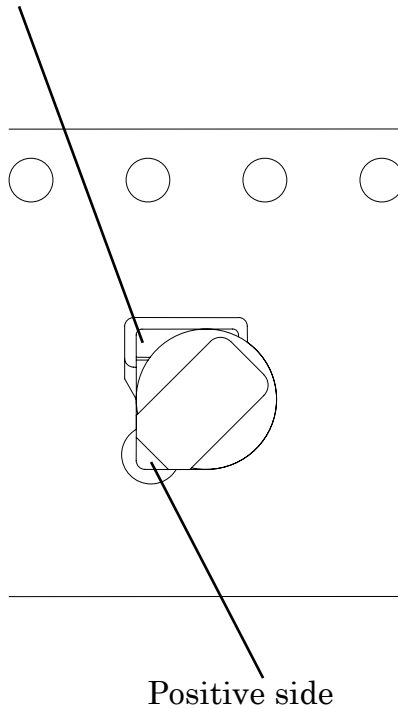

3. Quantity / reel

MAX. 4000 pcs / reel

Seiko Instruments Inc.

(Notes) There is no part lack in the component section.
 (注) 製品部分には、部品欠落の無いこと

Trailer section length : min 160mm
 トレーラー部長さ : 160mm 以上

Hub (material: foaming styrene)
 ハブ (材質: 発泡スチロール)

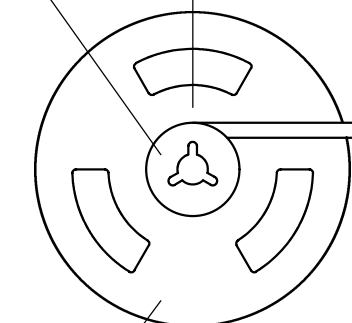
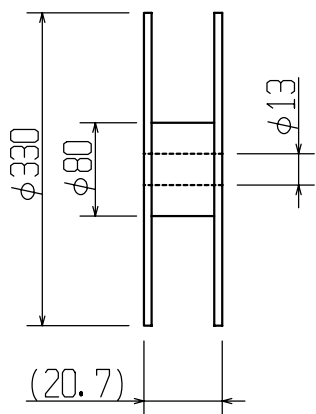

Reel (material: carton)
 リール (材質: 段ボール)

Leader section length : min 400mm
 リーダー部長さ : 400mm 以上

Carrier tape (material: Polystyren)
 キャリアテープ (材質: ポリスチレン)

Drawing direction
 引き出し方向

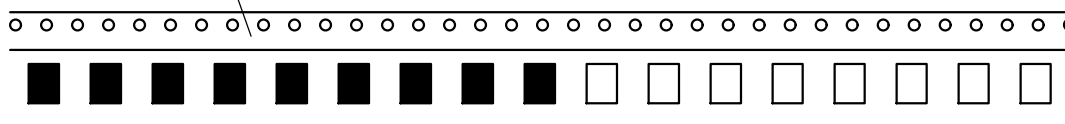

Component section
 製品部分

Empty Carrier tape sealed with top cover tape (material: PET) : min 400mm
 カバーテープ (材質: PET) シール付き空ポケット部長さ : 400mm 以上

Leader section length : min 400mm
 リーダー部長さ : 400mm 以上

				Fail No. 汎用番号	3177ON16-00000-1
				Date 日付	09. May. '03
E03A-020	09. May. '03	設定		Name 名称	Taping specifications
History 履歴	Date 日付	Reason 理由		Name 名称	テーピング仕様
Approved 承認	Checked 検査	Drawn 製図	Scale 尺度	Cal. No. 製品番号	_____
山田	冨塚	尾形	Unit 単位	1=1mm	Drw. No. 図面番号
			Rev. 改訂	1	
					3177 ON16

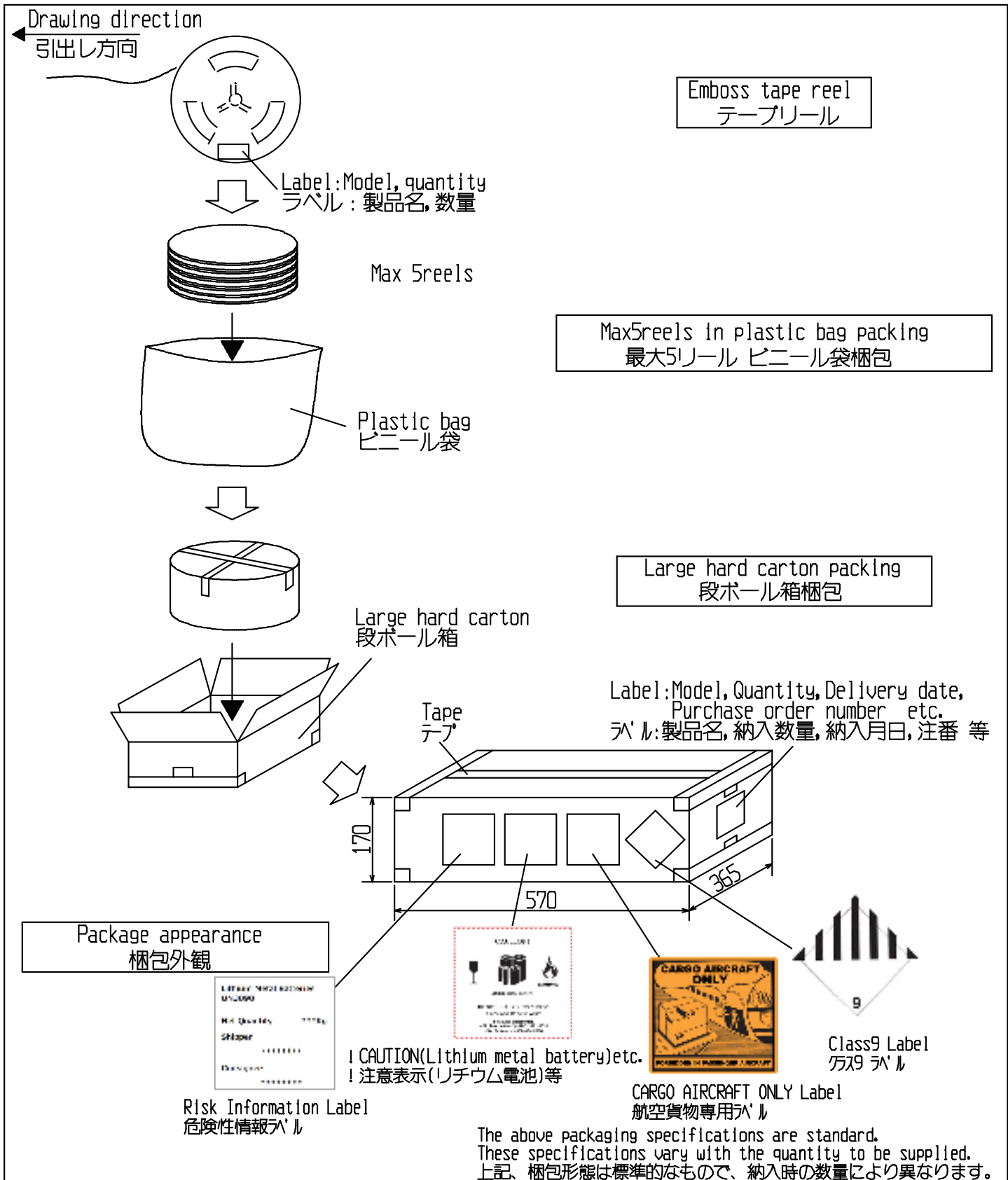

			File No. 文件番号	31770A76-00001B2
E16B-007	Aug. 24, 2016	最大数量、マスターカートンサイズ変更	Date 日付	Mar. 09, 2016
E16A-004	Mar. 09, 2016	設定	Name 名称	Package specifications(Section I B) 梱包仕様(Section I B)
History 履歴	Date 日付	Reason 理由	Cal. No. 製品番号	A76-01B
Approved 承認	Checked 検査	Drawn 製図	Scale 尺度	1=1mm
尾形		高野	Unit 単位	
			Rev. 改訂	2
			Draw. No. 図面番号	3177 0A76-1B

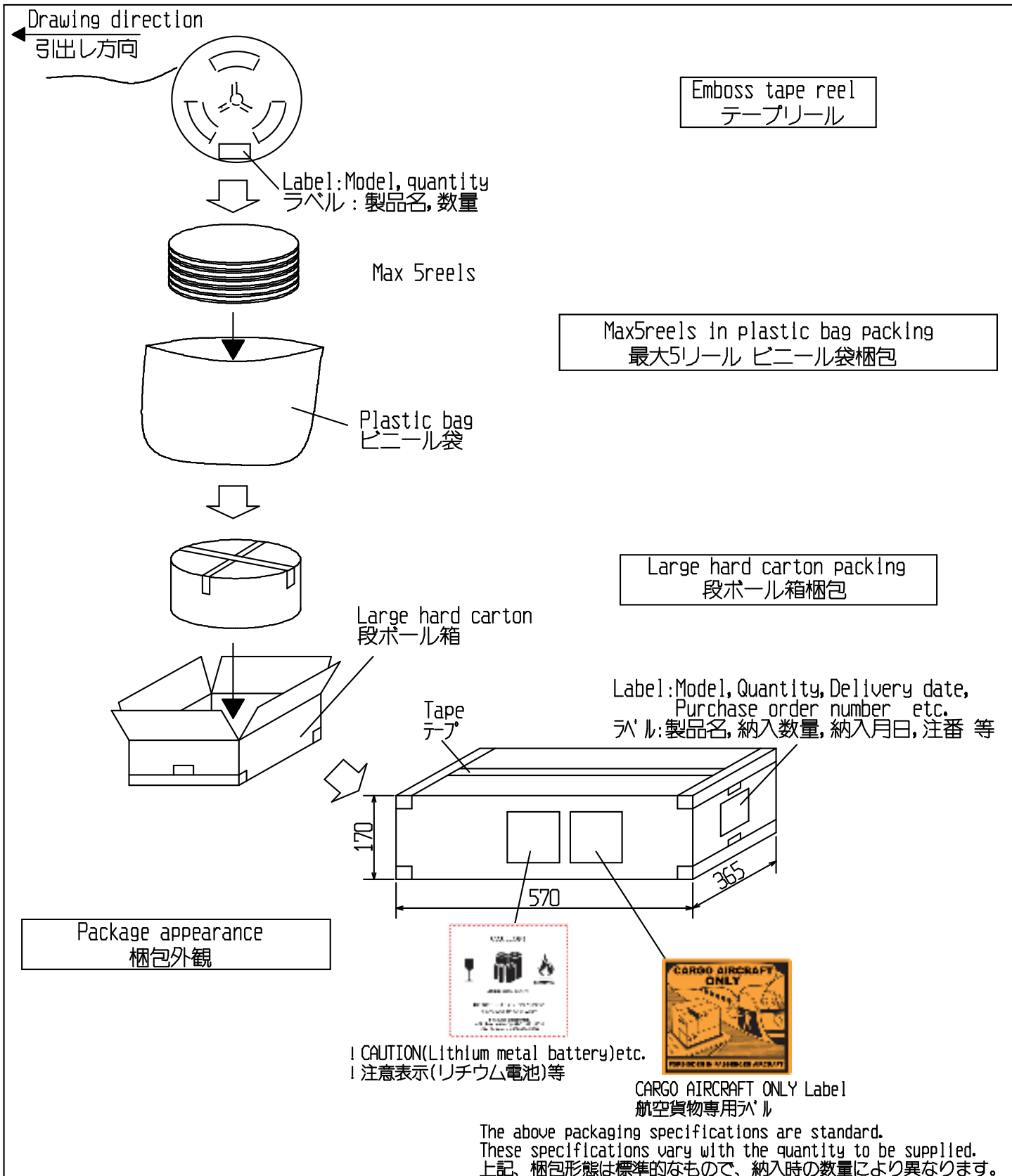

			File No. ファイル番号	31770A76-00002-2
E16B-007	Aug. 24, 2016	最大数量、マスターカートンサイズ変更	Date 日付	Mar. 09, 2016
E16A-004	Mar. 09, 2016	設定	Name 名称	Package specifications(Section II) 梱包仕様(Section II)
History 履歴	Date 日付	Reason 理由	Cal. No. 製品番号	A76-02
Approved 承認	Checked 検査	Drawn 製図	Scale 尺度	
尾形	/	高野	Unit 単位	1=1mm
			Rev. 改訂	2
			Draw. No. 図面番号	3177 0A76-2

Precautions for Your Safety

SII Lithium rechargeable batteries (MS, ML, TS) contain flammable organic solvents. For your safety, please follow following prohibitions.

WARNING!

- 1. Do not charge by high current or high voltage.**
Doing so may generate gas inside the battery, resulting swelling, fire, and heat generation or bursting.
- 2. Do not heat, disassemble nor dispose of in fire**
Doing so damages the insulation materials and may cause catching fire, heat generation, leakage or bursting.
- 3. Do not solder directly to the battery**
If soldering is performed directly to the battery, the battery is heated up, consequently cause leakage, explosion or fire due to overheating from internal short-circuit.
- 4. Do not short.**
If the (+) and (-) come into contact with metal materials, short-circuit occurs. As a result, fire, heat generation, leakage or bursting may occur.
- 5. Keep batteries out of children's reach.**
It is dangerous that children swallow the battery.
When you design mechanical hardware around the battery, please fix the battery firmly in order to prevent children from removing it.
When you store the batteries, please keep the batteries out of children's reach.
If a battery is swallowed, consult a physician immediately.
- 6. Do not reverse placement of (+) and (-)**
If the (+) and (-) side of the battery is reverse inserted, it may cause a short-circuit or over discharge of the battery on some equipment and it may induce overheating, explosion or fire.
- 7. Do not weld terminals to the battery**
The heat by welding may cause fire, heat generation, leakage or bursting.
We weld standard terminals under strictly controlled conditions.
If you need to weld terminals to the battery, please consult us in advance.
- 8. Do not discharge by force**
If the battery is discharged by direct connection to an external power supply etc., voltage of the battery will decline lower than 0 volts (electrical reversal) and will cause the battery case to expand, overheat, leak, explode or burn.
- 9. In case of leakage or a strange-smell; keep away from fire to prevent ignition of any leaked electrolyte.**
- 10. In case of disposal, insulate between (+) and (-) of battery by an insulating material.**
Jumbling batteries or with other metal materials cause short-circuiting. As a result, fire, heat generation, leakage or bursting may occur.

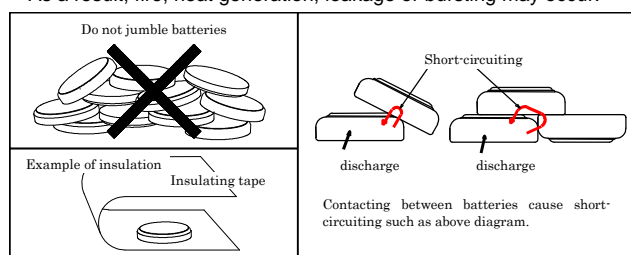

CAUTION!

- 1. If leaked liquids gets in the eyes, wash them with clean water and consult a physician immediately.**
- 2. Do not use new and used batteries together. Do not use different types of batteries together.**
It may cause fire, heat generation, leakage or bursting.
- 3. If you connect two or more batteries in series or parallel, please consult us in advance.**
It may cause bursting or fire due to unbalanced load or voltage.
- 4. Do not use nor leave the batteries in direct sunlight, nor in high-temperature areas.**
It may cause fire, heat generation, leakage or bursting.
- 5. Do not apply strong pressure to the batteries nor handle roughly.**
It may cause fire, heat generation, leakage or bursting.
- 6. Avoid contact with water.**
It may cause heat generation.
- 7. Keep batteries away from direct sunlight, high temperature and humidity.**
It may cause heat generation or performance deterioration.
- 8. Do not make batteries airtight by sealing it with adhesive agent or coating agent.**
It may cause short-circuit because of generated and accumulated electrolyte gas.

For prevention the performance of battery

- 1. Pay attention to mat or sheet for ESD**
Battery with tabs or battery on PCB may short circuit on the mat for ESD. As a result, the voltage of the cell is reduced.
- 2. Pay attention to soldering by iron tips**
Do not touch the battery by soldering iron tips directly.
Keep any high temperature process away from battery.
- 3. Pay attention to material of jig for pick and place**
Use non-conductive material of jig for pick and place of batteries in order to prevent short-circuit. If short circuit of battery is occurred, the voltage of battery drops down quickly but raises gradually.
- 4. Pay attention to washing and drying**
Some detergent or high temperature drying cause deteriorates of battery. If you need to wash batteries, consult us.

International Transportation and Disposal

International Air / Marine / Ground Transportation

Regarding the transport of Lithium battery, organizations like IATA, ICAO, IMO, DOT have determined transport regulations, based on the United Nations Regulations.

Regarding air transport, SII Lithium rechargeable batteries can be transported being not subject to the provisions of dangerous goods, if the transportations meet the following requirements.

Please contact us for more details.

Regarding marine or ground transport, please contact us for more details, too.

(a) <Strong Packaging> Batteries are separated each other, and are packed in strong packaging so as to prevent short-circuit.

(b) <Caution Label> Lithium battery handling label (IATA prescribed), indicating that the packages contain Lithium batteries, that the packages must be handled with care, and that special procedures should be followed in the event that the package is damaged, and a telephone number for additional information, must be put on each package.

(c) <CAO Label> "CARGO AIRCRAFT ONLY" Label must be put on each package.

(d) <Not Restricted Declaration> Each shipment must be accompanied with a document indicating that the packages contain Lithium batteries, that the packages must be handled with care, that it must not be transported by

passenger flight, and that special procedures should be followed in the event that the package is damaged, and a telephone number for additional information.

(e) <Package Drop Test> Each package is capable of withstanding a 1.2m drop test in any orientation without damage to batteries contained.

(f) <Weight Limit> Net weight of one package may not exceed 2.5 kg.

(g) <One carton per one shipment> The shipment must be "one carton per one shipment" to be shipped as "Non-dangerous goods".
"One shipment" means one airway bill = one invoice.

【Transport as dangerous goods】

When you transport SII's Lithium rechargeable batteries by "more than one carton per one shipment", you will have to arrange it as "Dangerous goods". It requires special procedures, like "Class 9 dangerous goods Label" on carton, and "dangerous goods declaration".

Disposal

Recently environmental protection regulations have increased and battery disposals are regulated globally.

Such regulations are different in each country, state, and municipality.

Please consult your local authorities regarding the specific regulations in your area.